

WALL RAIL DETAIL

TYPICAL RAILING ELEVATION

NOTE:

- OTHER PIPE OR TUBE SIZES AVAILABLE.
- ALSO AVAILABLE IN STAINLESS STEEL.

RAIL STYLE: ALUM WALL RAIL		DWG NO. WR-1.5	REV 0
4550 Old Meadville Rd		DATE	SHEET 1 of 1
PH: 814.796.4515		SCALE	
FX: 814.796.4009			



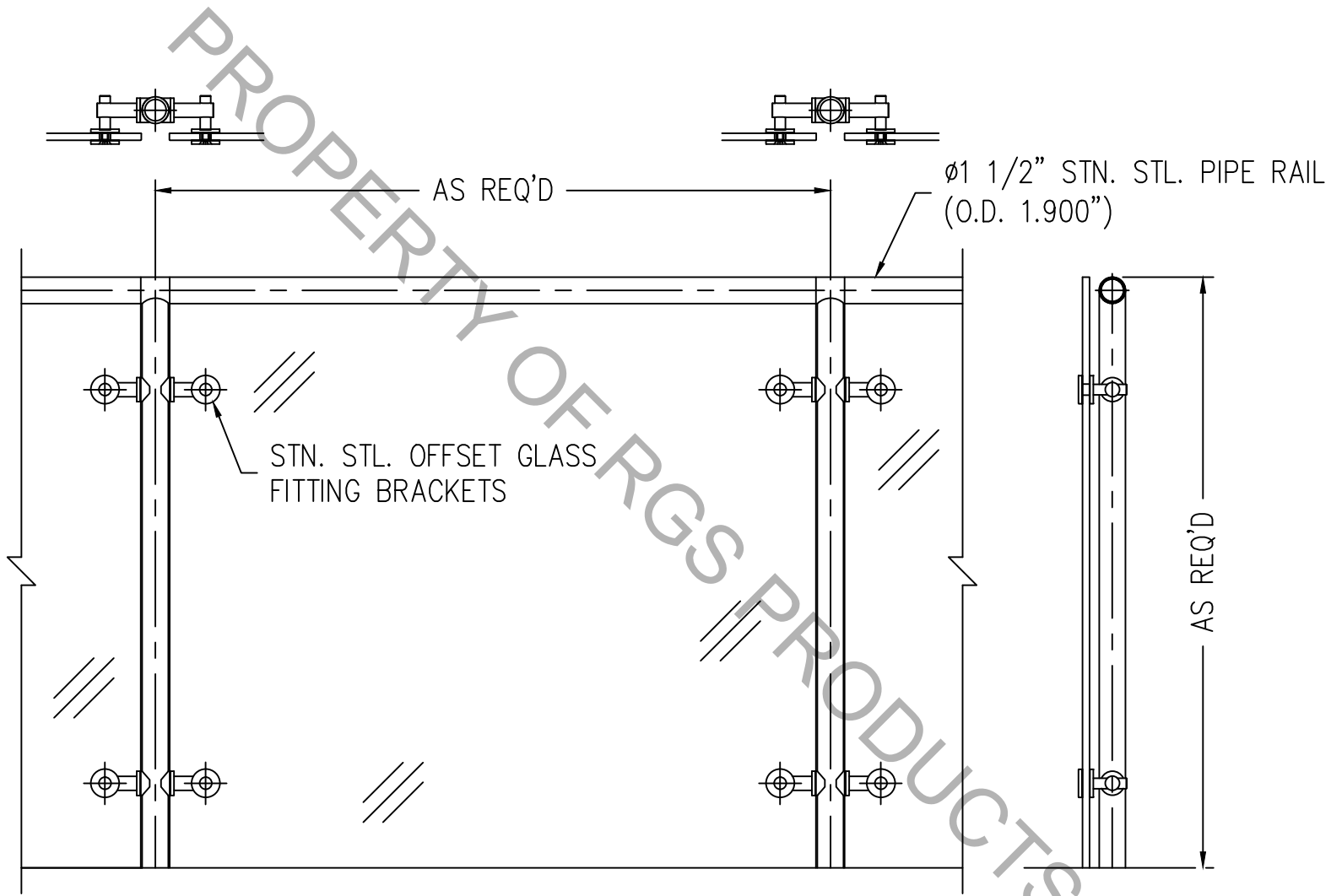

TYPICAL RAILING ELEVATION

PROPERTY OF RGS PRODUCTS, INC.

4550 Old Meadville Rd		POINT MOUNTED GLASS	
PH: 814.796.4515	DWG NO. PMG--1	REV 0	REV 0
FX: 814.796.4009	SCALE	DATE	SHEET 1 of 1



Ø1 1/2" SCH 40 ALUM PIPE
(O.D. 1.900" x .145" WALL)

WELD ALL AROUND AS CAST
(WELDS CAN BE GROUND SMOOTH)

Ø1 1/2" SCH 40 ALUM PIPE
(O.D. 1.900" x .145" WALL)

Ø1 1/2" SCH 40 ALUM PIPE
(O.D. 1.900" x .145" WALL)

RAILING CROSS SECTION

NOTE:

- OTHER PIPE OR TUBE SIZES AVAILABLE.
- ALSO AVAILABLE IN STAINLESS STEEL.

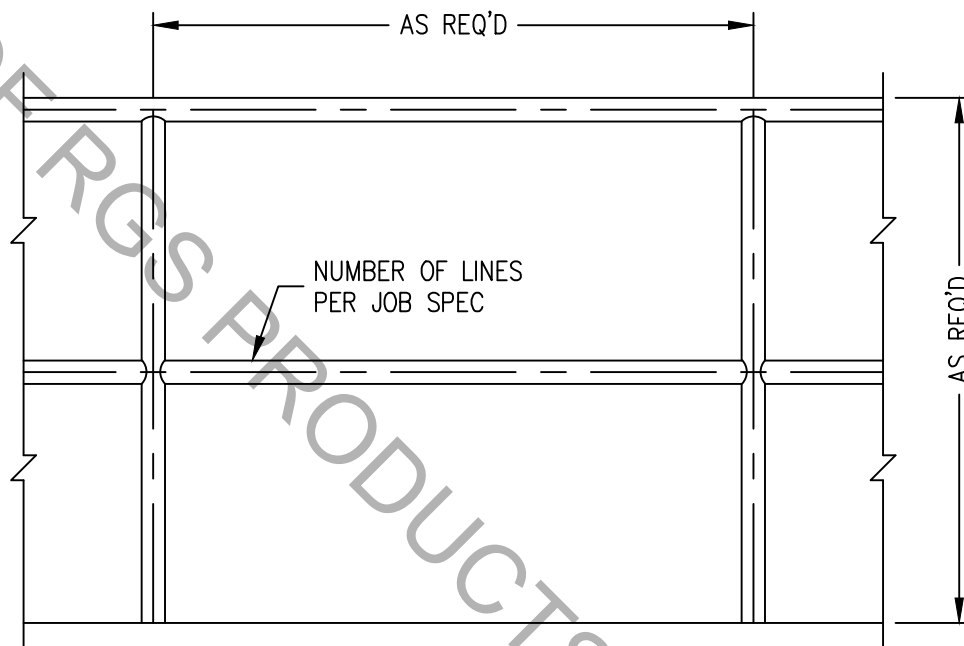

TYPICAL RAILING ELEVATION

ALUM PIPE RAIL

RAIL STYLE:

4550 Old Meadville Rd

PH: 814.796.4515

FX: 814.796.4009

FINISH

DWG NO. P-1.5

REV 0

SCALE

DATE

SHEET

1 of 1

